

Code No: 156AB

JAWAHARLAL NEHRU TECHNOLOGICAL UNIVERSITY HYDERABAD

B. Tech III Year II Semester Examinations, February/March - 2022

ADVANCED STRUCTURAL ANALYSIS

(Civil Engineering)

Time: 3 hours

Max. Marks: 75

Answer any five questions
All questions carry equal marks

- - -

- 1.a) Using suitable examples, explain the static indeterminacy and kinematic indeterminacy of different structures.
- b) Derive the force-displacement equation for a truss element. [10+5]
- 2.a) Explain banded matrix and semi band width. Give examples how band width can be reduced with nodal numbering scheme.
- b) How to assemble the individual stiffness matrices? [10+5]
3. Analyze the continuous beam shown in figure 1 below. Assume EI as uniform. Use Matrix flexibility method. [15]

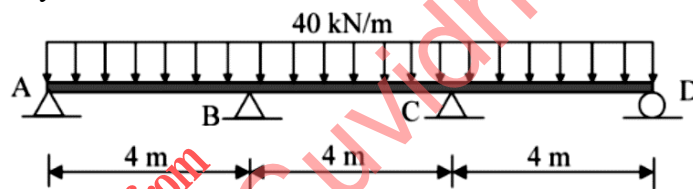

Figure 1

- 4.a) Generate the stiffness matrix for the structure with coordinates as shown in Figure 2.

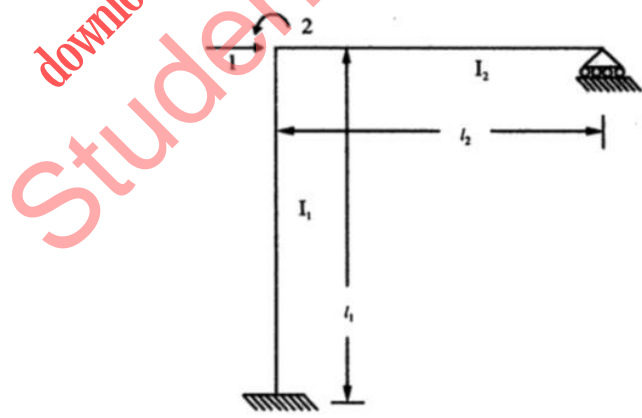

Figure 2

- b) Analyse the continuous beam shown in figure 3 by stiffness matrix method. [5+10]

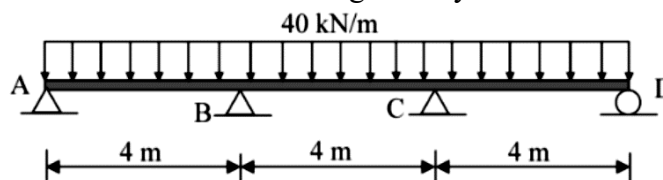

Figure 3

5. Analyze the continuous beam shown in figure 4 below by stiffness method. Draw bending Moment diagram and elastic curve. [15]

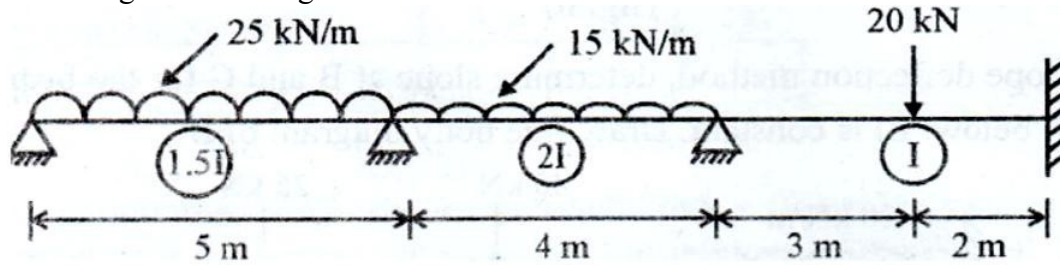

Figure 4

- 6.a) Explain the steps involved in assembly of stiffness matrix with suitable examples.
 b) Explain the transformation of co-ordinates with a suitable example. [10+5]
7. Analyze the portal frame ABCD shown in figure 5 below by flexibility matrix method and sketch the bending moment diagram. [15]

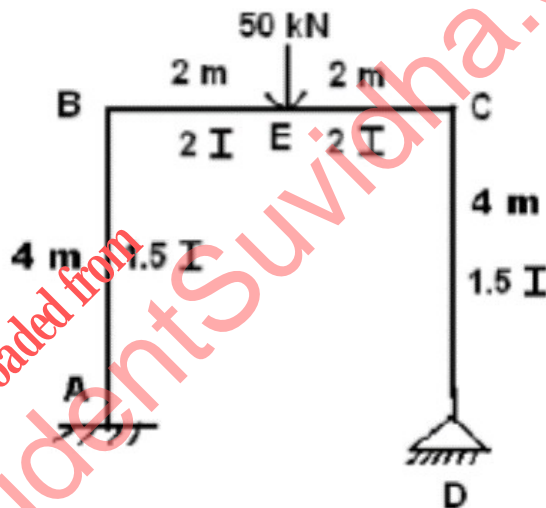

Figure 5

- 8.a) Explain the structural behavior of large frames with and without shear walls.
 b) Explain about static condensation technique. [8+7]

---ooOoo---